

MAX 100~125KTL3-X LV

- 10 MPPTs fusefree design
- Smart I/V scan and diagnosis
- Intelligent string monitoring
- AC&DC type II SPD
- IP66 and C5 protection

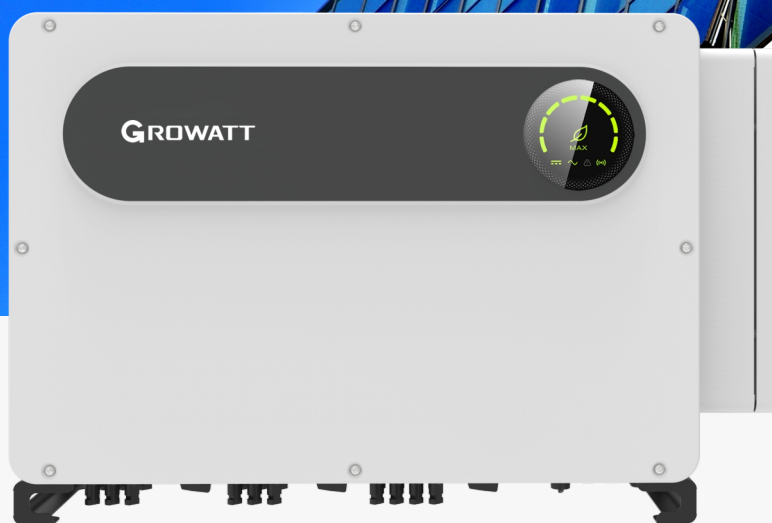

Topology Diagram

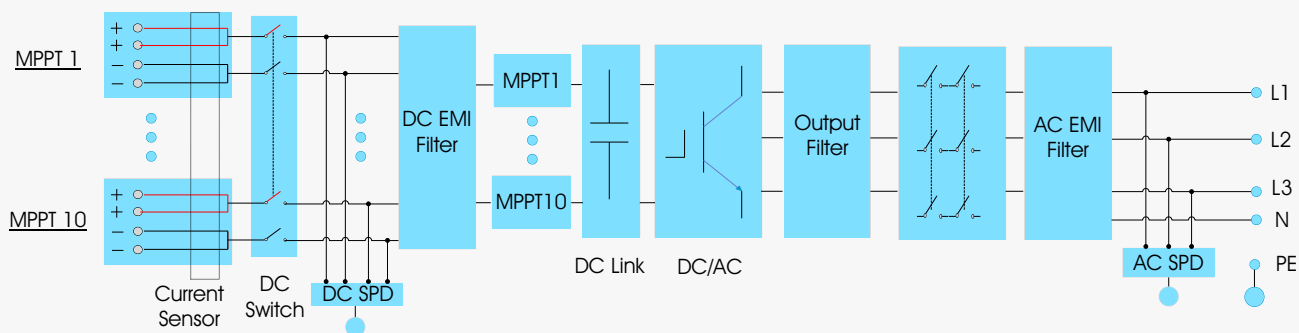

Primary Specification

Datasheet	MAX 100KTL3-X LV	MAX 110KTL3-X LV	MAX 120KTL3-X LV	MAX 125KTL3-X LV
Input data (DC)				
Max.DC power	150kW	165kW	180kW	187.5kW
Max. DC voltage	1100V			
Start voltage	195V			
Nominal voltage	600V			
MPP voltage range	180V-1000V			
No. of MPP trackers	10			
No. of PV strings per MPP tracker	2			
Max. input current per MPP tracker	32A			
Max. short-circuit current per MPP tracker	40A			
Output data (AC)				
AC nominal power	100000W	110000W	120000W	125000W
Max. AC apparent power	110000VA	121000VA	132000VA	137500VA
Nominal AC voltage(range*)	400V/380V(340-440VAC)			
AC grid frequency (range*)	50/60 Hz(45~55Hz/55-65 Hz)			
Max. output current	158.8A@400V 167.1A@380V	174.6A@400V 183.8A@380V	190.5A@400V 200.5A@380V	198.5A@400V 208.9A@380V
Adjustable power factor	0.8leading ...0.8lagging			
THDI	<3%			
AC grid connection type	3W/N/PE			
Efficiency				
Max. efficiency	98.8%			
European efficiency	98.4%	98.5%	98.5%	98.5%
MPPT efficiency	99.9%			
Protection devices				
DC reverse polarity protection	Yes			
DC switch	Yes			
AC/DC surge protection	Type II / Type II			
Insulation resistance monitoring	Yes			
AC short-circuit protection	Yes			
Ground fault monitoring	Yes			
String detection	Yes			
Anti PID function	Opt			
Arc fault detection (AFCI)	Opt			
General data				
Dimensions (W / H / D)	970/640/345mm			
Weight	84kg			
Operating temperature range	-30°C ... +60°C			
Nighttime power consumption	< 1W			
Topology	Transformerless			
Cooling	Smart Cooling			
Protection degree	IP66			
Relative humidity	0~100%			
Altitude	4000m			
DC connection	H4/MC4 (Max.6mm ²)			
AC connection	OT Terminal (Max. 240mm ²)			
Display	LED/WIFI+APP			
Interfaces: RS485 / USB /PLC/GPRS/4G/WIFI	Yes/Yes/Optional/Optional/Optional/Optional			
Warranty: 5 years / 10 years	Yes /Optional			
CE,IEC62116, IEC61727, CQC, VDE0126, VFR2019, EN50549-1/2, C10/C11, UNE206007, G99 CEI 0-21/0-16, N4105&N4110, UNE206006, MEA, PEA, KSC8565				

* The AC voltage range and frequency range may vary depending on specific country grid standard.
All specifications are subject to change without notice.